



All Theses and Dissertations

2008-06-30

Development of a Particle Flow Test for Rotational Molding

Russell B. Whatcott

Brigham Young University - Provo

Follow this and additional works at: <https://scholarsarchive.byu.edu/etd>

 Part of the [Construction Engineering and Management Commons](#), and the [Manufacturing Commons](#)

BYU ScholarsArchive Citation

Whatcott, Russell B., "Development of a Particle Flow Test for Rotational Molding" (2008). *All Theses and Dissertations*. 1526.
<https://scholarsarchive.byu.edu/etd/1526>

This Thesis is brought to you for free and open access by BYU ScholarsArchive. It has been accepted for inclusion in All Theses and Dissertations by an authorized administrator of BYU ScholarsArchive. For more information, please contact scholarsarchive@byu.edu, ellen_amatangelo@byu.edu.

DEVELOPMENT OF A PARTICAL FLOW TEST FOR
ROTATIONAL MOLDING

by

Russell B. Whatcott

A thesis submitted to the faculty of

Brigham Young University

in partial fulfillment of the requirements for the degree of

Master of Science

School of Technology

Brigham Young University

August 2008

BRIGHAM YOUNG UNIVERSITY

GRADUATE COMMITTEE APPROVAL

of a thesis submitted by

Russell B. Whatcott

This thesis has been read by each member of the following graduate committee and by majority vote has been found to be satisfactory.

Date

A. Brent Strong, Chair

Date

Kent E. Kohkonen

Date

Dennis L. Eggett

BRIGHAM YOUNG UNIVERSITY

As chair of the candidate's graduate committee, I have read the thesis of Russell B. Whatcott in its final form and have found that (1) its format, citations, and bibliographical style are consistent and acceptable and fulfill university and department style requirements; (2) its illustrative materials including figures, tables, and charts are in place; and (3) the final manuscript is satisfactory to the graduate committee and is ready for submission to the university library.

Date

A. Brent Strong

Chair, Graduate Committee

Accepted for the School

Barry M. Lunt

Graduate Coordinator

Accepted for the College

Alan R. Parkinson

Dean, Ira A. Fulton College of Engineering
and Technology

ABSTRACT

DEVELOPMENT OF A PARTIAL FLOW TEST FOR ROTATIONAL MOLDING

Russell B. Whatcott
School of Technology
Master of Science

One of the current testing method (the Dry Flow test) to qualify resin for use in production in the rotomolding process has been shown to have many flaws in both equipment and procedure. Research was done here to investigate a possible alternative that could eliminate some of these testing deficiencies. By reducing equipment and operator errors, the testing of materials becomes more valuable of an exercise. The Angular Flow test developed in this research can increase repeatability. By coming to understand the rotational molding process better, an evaluation that can give more valid information was devised.

ACKNOWLEDGMENTS

I would like to thank my professors, especially my mentor and advisor, A. Brent Strong. By sharing insight in things both exciting and mundane he has enriched my life and heightened my ability to see beyond what is there to what should be there.

I would also like to thank Brigham Young University for, of all things, requiring that I take classes that have nothing to do with what I want. By broadening my horizons you have opened doors that were invisible and invaluable. For me, at least, it definitely worked.

I would like to, most importantly, thank my wonderful wife for all her support and patience. Without her help in so many aspects of life, this work would not have been possible. By being my best friend, my first editor, my taskmaster and my interested audience you have made me who I am. I love you.

TABLE OF CONTENTS

LIST OF TABLES.....	viii
LIST OF FIGURES	ix
1 Background and Thesis of this Work.....	1
1.1 Plastics Processes	1
1.2 Need for Examining Rotomolding	3
1.3 Proposal	6
1.4 Thesis Statement.....	6
1.5 Delimitations	7
2 Review of Literature	8
2.1 Plastics Manufacturing Methods	8
2.2 Rotomolding Equipment.....	14
2.3 Rotomolding Process	15
2.4 Sintering Process Materials	23
2.5 Powdered Resin Testing.....	26
3 Experimental Procedure.....	32
3.1 Need for a New Test	32
3.2 Development.....	36
4 Results	45
4.1 Results.....	45
4.2 Results From the Dry Flow Test	46
4.3 Results From the Angular Flow Test	47

4.4 Statistical Analysis	50
5 Conclusions and Recommendations.....	52
5.1 Conclusions.....	52
5.2 Suggestions	54

LIST OF TABLES

Table 4A Test Results from the Dry Flow Test	48
Table 4B Test Results from the Angular Flow Test	49

LIST OF FIGURES

Figure 3A Sample Rotomolded Part	34
Figure 3B Concave Angular Flow Test Fixture	37
Figure 3C Concave Angular Flow Bottom Plate 0.38 Inch Hole	38
Figure 3D Concave Angular Flow Bottom Plate 0.50 Inch Hole	39
Figure 3E Concave Angular Flow Bottom Plate 0.78 Inch Hole.....	39
Figure 3F Convex Angular Flow Test Fixture	41
Figure 3G Convex Angular Flow Test Fixture: Up Position	42
Figure 3H Convex Angular Flow Test Fixture: Testing	43
Figure 3I Convex Angular Flow Test Fixture: Down Position	43

BACKGROUND AND THESIS OF THIS WORK

1.1 Plastics Processes

Plastics manufacturing is a vital part of manufacturing worldwide. With all of the materials and processes now available in the plastics industry, many products that were once made from other heavier and more expensive materials can now be made from plastic. Plastic parts can typically be made faster and lighter but, often more importantly, they can be made less expensively than metals, ceramics, or natural polymers such as wood. The greatest plastics penetration of markets has been where the benefits of low cost manufacturing and/or lighter weight are the most prevalent. The cost of manufacturing is often directly related to the temperature at which a material is processed. Higher temperatures required to shape metals and ceramics usually lead to higher costs of production than equivalent plastic materials. Another key property in determining the cost of manufacture is the production rate. Therefore, in examining the various plastic production processes, these two factors — processing temperature and production rate — are critical in determining the cost of production.

Injection molding and extrusion, where the material is melted through an external heat input and through mechanical mixing, are often the most cost effective of the plastics processes because of the extremely high production rate. Over the last several years these

processes have continued to grow and develop. Because of their prevalence, they can be used as standards against which other plastics processing methods can be compared.

Besides injection molding and extrusion, other plastics processes have been developed that show some of the benefits of costs and productivity and have certain advantages over injection molding and extrusion for some parts but, of course, also have some disadvantages. These other processes include, but are not limited to, processes in which the resin is already a liquid and, therefore, no melting is required. Compression molding and casting are two such processes. However, liquid resins require chemical reactions to solidify (cure) the plastic resin and that curing process often takes considerable time. Therefore, productivity rate is usually lower for these processes than for injection molding and extrusion. However, the liquid processes allow the inclusion of fiber reinforcements which can substantially add to the strength and stiffness of the final part. The fiber reinforced processes include filament winding, pultrusion, and compression molding. In the fiber reinforced plastic processes, part strength on a weight basis can generally be engineered to exceed that of the metal parts that they typically replace. However, these parts are not always made quickly or inexpensively.

Some plastics processes only soften the plastic rather than melt it or cure it. Thermoforming is the most common of these processes. The cost of manufacturing is often quite low but the cost of the raw material (usually in a sheet form) is much higher than the raw material (pellets) used in injection molding and extrusion. The amount of waste material (trimmings) in thermoforming is also higher than in extrusion or injection molding.

The principal sintering process for plastics is rotational molding (also called rotomolding). In this process the plastic is not fully melted but is supplied in a relatively inexpensive powder form, thus saving the costs of using a finished product such as a sheet. Rotomolding is generally capable of producing hollow parts, specifically, large hollow vessels, tanks, drums and large garbage cans. Sometimes these large hollow vessels are quite complex and detailed. These types of parts are difficult to make in injection molding and other high-throughput processes. Furthermore, the mold costs for such parts would be prohibitive in injection molding. However, the costs of molds for rotomolding are comparatively very low. Another advantage to rotomolding is that part wall thickness can be changed without a change to the mold. If any part being produced is seen to fail because of wall thickness, the walls can be increased by simply adding more resin to the charge put into the mold. The cycle time will also need to be lengthened, but the additional resin will simply be added to the inside surface of the part. The main disadvantages that hinder rotomolding from greater use are the long cycle times and the limitation to hollow parts.

Anytime a part is designed, the various benefits and drawbacks of the potential process should be weighed. By careful consideration, the correct process for a particular product can be chosen. With some parts, many processes are naturally eliminated because of an inability to fulfill all part requirements. For example, large hollow vessels can not be made by injection molding. Parts with a non-uniform cross-section can't be made by extrusion. Therefore, the process used to make a part should be carefully considered.

1.2 Need For Examining Rotational Molding

Of all the plastic manufacturing processes, rotational molding is probably the least developed and yet it has great potential for expansion into new parts and new markets. The increasing use of rotational molding for toys suggests that the productivity rate for this process is being increased greatly. Also, the recent introduction of products such as rotomolded fences shows that the requirement of parts being hollow may not be as much a limitation in design as previously thought. Therefore, a closer study of some of the critical factors in rotational molding is appropriate at this time.

The process itself takes a great deal of time because of the sintering of the resin. Softening, fusing and degassing the material are all part of the sintering that occurs in the rotomolding process. Because all the heat is transferred conductively through the mold and into the resin, the softening takes a great deal of time. Unfortunately, there can be no mechanical heating or softening of the material, which in most processes reduces the total cycle time. This time concern can be readily offset, however, by molding multiple parts at the same time, effectively reducing the cycle time per part. A rotomolding machine has arms that hold the molds. Often these arms are fitted with plates or grids to which the molds can be fastened. If care is taken to allow for adequate air circulation around and through all the molds that are mounted to the grids, the grid can be fitted with as many molds as the grid can accommodate. Besides being heated, each of the various molds that are mounted will also need to be opened, filled and emptied. Unlike other processes, each mold on the mounting grid can be of different parts and even different materials because

the material is fully contained within the mold and is never processed through the main machine.

The most common resin used in rotomolding, polyethylene, is among the lowest priced of all plastic resins. However, the materials used in rotomolding must undergo an additional process before they can be used. After compounding and pelletizing the materials (as is done for injection molding and extrusion), the plastic pellets must then be pulverized into a fine powder. This powder is needed because of the sintering nature of the rotomolding process. This material, though, is not as costly as material used in most of the fiber reinforced processes or the thermoforming process and is now readily available.

The quality control in rotomolding is a large concern. Some molders have to charge increased rates because of scrap rates of up to 30% or even higher. This can sometimes be attributed to mold complexity or insufficient process control but might also be caused by inadequate control over the nature of the pulverized resin. Traditionally, the methods of controlling the quality of the pulverized resin are highly variable and do not afford proper quality measurements. The current methods of quality control testing on the resin are called the dry flow test and bulk density test. The dry flow test consists of a specified funnel wherein a measured amount of material is placed. The time that this amount of material takes to flow out of the funnel becomes the measurement of flow for the material. As the material flows from the funnel, it falls into a measured cup that has been weighed before the test. This cup is then scraped even with the top to get a measurement of bulk density. These two tests are the basic quality control measures in

use for testing pulverized material before molding it. The dry flow test, however, has been shown to be susceptible to operator error as well as have equipment deficiencies. Furthermore, the nature (shape) of the pulverized particles is a factor that strongly affects the results of the test. In some cases, the resin will not even flow in the test, thus rendering the test invalid. Understanding these weaknesses can allow for good internal measures and controls but greatly reduces the test's universal effectiveness.

In order to have a universal test that can be performed, passing valuable information between suppliers and manufacturers, there must be a change. There needs to be a test that will be universally usable with very little chance for equipment deficiencies or operator error. This test equipment must be easily reproducible so that each QC lab can create or purchase the equipment necessary to perform the test. As this test is developed, at some point, there must be some additional independent verification in order for this test to become of widespread use. As broad use becomes more common, the test, and its results, will only become more valuable. Besides giving valuable information that can aid in the processing of each part, the test will give valuable information that can be used in ordering and receiving new materials.

1.3 Proposal

This research will develop a new quality control test that can potentially work alongside or in place of the dry flow test. This work will delineate some of the optimal functions and features of this new test.

The new proposed test consists of two cylinders. One will be the base cylinder and the other will be the sliding cylinder. The base cylinder will have a measuring device attached at the top. The sliding cylinder will begin the test positioned the top of the base cylinder, leaving a cup-like shape to hold the powder. The diameter of the base cylinder will be about 4 inches and the height of the cup area created between the two cylinders should be another 50% higher than that diameter. This should allow for all potential materials as anything that would have less flow would be above that limit but would also be unsuitable for the rotomolding process. The final measurement or results from this test will be either a ratio of height to diameter or an angle. This will be a more universal measurement that removes variations in equipment diameter.

1.4 Thesis Statement

In order to verify that success has been achieved, objectives must be set. This research proposes to show that the concept of the cylinder-based powder interaction is a test that can be performed routinely and that it will give results in testing rotomolding resins that are comparable to or better than the present resin testing method. Once this testing is completed, the test results will be compared directly with the test results of the current test method. These tests will be conducted on comparable materials in a controlled environment.

1.5 Delimitations

This research will not solve all the concerns with the cylinder-based powder interaction testing method. The research does not propose to remove all of the concerns that reduce the efficacy of the current dry flow testing. The research does propose to present the results of the new proposed testing equipment as either valid for further significant review or as severely lacking and not an effective test for in depth study and refining. This will be done by testing both production materials and also some experimental resins. These will all be tested on both the current dry flow test as a benchmark as well as the new proposed testing system. The statistical analysis of the two methods will allow for an even comparison of the two and help to determine the value of the new test.

REVIEW OF LITERATURE

2.1 Plastics Manufacturing Methods

Among the many different manufacturing processes in use today, plastics processes are becoming far more prevalent (Miller 1981). Plastics products are extremely versatile and production costs often more economical than comparable parts made through other methods and from other materials (Belofsky 1995). Among the various ways to classify the various molding methods, one would be to link them by what happens to the resins during processing. Using this system of classification, four possible categories would be melt processes, cure processes, soften processes and sinter processes. Melt processes would be those where material is softened as heat is applied conductively while they are also mechanically agitated. Cure processes would be those where thermoset material is placed in a mold and crosslinking occurs within the resin to the point that it can take the shape of the mold, harden and be removed. Heat can be applied in cure processes to shorten cycle times. In the softening processes material is pre-processed to the general form it is needed before the final process. It is then softened in an oven or heat convection apparatus and while still soft the material is formed to a mold. The fourth category would be sintering processes. This would be the processes where material is placed into a mold in some particle form. This particle material is then heated to a softening point. As the material softens it begins to fuse and the air that is naturally

trapped in the structure ideally migrates out. Rotational molding or rotomolding is the main process in this last category of sintering processes.

Melt processes are the main processes used in high volume production of commodity plastic parts and also many highly engineered high cost parts. These are the processes that have the highest throughput of material. Extrusion, for example, is a continuous process which “makes possible high production volumes, thus making it the least expensive forming method” (Strong, 2006). The material used in these processes is purchased in pellet form. The pellet material is placed in some sort of automatic material feeder that often has the ability to remove any moisture that accumulates in the material during storage and transportation. After being dried, if it is needed, the material is fed towards the machine. In the machine the material is transported through the mouth opening into a heated barrel with an engineered screw. The screw is designed in sections so that it can feed, compress and then meter the appropriate amount of material into the section where it will be molded. Between the heated barrel and the mechanical action of the screw, the material is melted only to the point where the molding step is possible.

The two main melt processes are injection molding and extrusion. The basics of the feed and melting portions of these two processes are quite comparable. In injection molding, “at the plasticizing stage, the feed unit operates pretty much as an extruder, melting and homogenizing the material in the screw/barrel system” (Harrier, 1991) It is in the forming portion of the two where the main differences arise. In extrusion, material is fed directly out the end of the barrel into a die. The die distributes the material appropriately and funnels it to the die opening. The die opening is often the shape of the

final part. The process then has a take-up mechanism to remove the formed material from the die after the extrudate has been sufficiently cooled. One of the most commonly extruded parts is tubing of varying shapes and diameters.

With injection molded parts, the hot, liquid resin is pushed into a mold that is clamped closed. Pressure is applied to the resin stream for a time as the plastic material cools to the mold temperature, thus ensuring that the plastic fills the mold cavity and solidifies as a dense material without voids. There is a degree of shrinkage that occurs during the cooling. Once the part is sufficiently cooled, the mold is opened and the part is removed. With injected parts, there is often a secondary operation of part cleanup that must remove the connecting material that allows transport of the molten resin from the barrel, in appropriate quantities, to the part cavities. One of the high volume injection molded parts is toys of many different sizes and shapes.

Because of the high volume output of these melt processes, they generally process material efficiently and cost effectively. Another advantage to melt processes is that most reject parts can be easily chopped to small chunks and reprocessed.

Softening molding is when the material is first molded into a shape that is convenient for further processing and then that material is softened and processed again into a mold with the desired dimensions. For example, in thermoforming, material is processed through extrusion into a sheet form. This sheet material is clamped into frame and heated above the material's glass transition temperature. This sheet is then placed against the mold and is drawn or pressed into the mold. This is typically either done with a vacuum assist or with positive air pressure to the material forcing it directly against the mold

(Flinn 1990). One disadvantage to thermoforming is that parts need to be trimmed after processing. Because of the clamping fixture used in thermoforming, there is often a great deal of scrap produced with every part.

Another example of a softening process would be injection blow molding used for making plastic soda bottles. In this process the material is injection molded into a blank that has some of the features that the final bottle will have up towards the neck of part but the rest of the part is much too small to function as desired. This blank is then placed into a fixture where the plastic can be softened and then the material is mechanically stretched in one direction with a push rod and then blown axially to the final diameter of the bottle. This not only allows for reasonably intricate sections, like threads, to be molded simply but it also allows for proper stretching that is needed for permeability reduction through internal crystal formation. Because the soften processes require the material to be pre-formed before use, there is an increase in material cost. Also, because the material has to be pre-formed, any scrap parts have to be ground and re-formed before they can be processed again. Unless a manufacturer has the preforming equipment, all scrap material is sold for a loss to a supplier than can then process this scrap into useful material. Within the blow molding process designation there are several variations in equipment, process and final product that make it a very useful process. “Although there are considerable differences in the processes available, . . . all have in common the production of a parison (a tube-like plastic shape), the insertion of the parison into a closed mold, and the injection of air into the mold where it sets up into the finished product” (Frados, 1976).

The next category of processes is the cure processes. These are the processes where parts are made from a thermoset material and then, after the material is placed into the mold, the resin is hardened through a chemical reaction. Because this chemical reaction process is generally slower than the simple cooling of the melt processes, the cure processes are often more expensive. However, because the resin is a liquid (before curing), cure processes are conveniently used to make composite or fiber reinforced parts. (The liquid resin can wet the fibers before molding whereas this can only be done with difficulty with melt processes.) The parts are made as the liquid resin is mixed with a curing agent. This can either be a hardener or catalyst that begins a chemical reaction. Sometimes the components do not begin to react until after the temperature of the material is increased beyond room temperature. This allows for the greatest pot life or working time between mixing and final cure. After mixing the resin, in composite parts, the resin is then added to the fiber materials and together the resin and fiber are applied to the mold or mandrel. One common cure process is filament winding, where the resin-wetted fibers are wound in long strands around a mandrel. These mandrels are either expandable or they have a draft angle so that the mandrel can be removed after the part has been cured. In another version of filament winding, sacrificial mandrels are made that can be wound on and then left inside the part after the part is finished. After applying the resin and fiber mix, the mold or mandrel is typically heated in some way. Many times this means the part and mold are placed inside an oven or autoclave, other times the mold itself is heated. Because of the fibers that are used in cure processing, these parts are typically much stronger than any of the other plastics parts. These parts can be used as

pressure vessels, high strength masts or aviation and aerospace parts. Cured parts are typically have a higher melt temperature than their decomposition temperature which means that nearly all scrap in these processes is lost and must be thrown out. Rather than being able to use the material again, the material will char and burn instead of softening for any processing value (Jacobs 1985).

Rotational molding or rotomolding is the main embodiment of a sinter process. There are other processes that employ sintering but most of them are low volume, specialty processes or can be classified as a type of rotomolding (Brydson 1989). Rotomolding, as a sintering process, is a low pressure plastics molding process. Its main advantage over other processes is that it is used to make hollow parts. These parts are usually large. Typical parts made through the rotomolding process include tanks (both large and small), garbage containers, barrels, and drums. Besides being able to produce large, hollow, one piece parts, there are also advantages to rotomolding that other processes can not offer because of the processing basics. Most of the larger parts made through rotomolding can only be made by fabrication or joining of materials. Whether it be plastic or metal, the large hollow vessels need to be made by connecting formed sheets of material through one of the various joining processes. Fabrication is a potential alternative but even with the large cycle times that are experienced in rotomolding, fabrication is often more expensive and time consuming.

2.2 Rotomolding Equipment

Rotomolding equipment consists of a heating system, a rotating mechanism, a cooling system and loading zone (Rosato 1991). The heating system is typically a large cube-shaped convection oven. The oven can be a standard oven system with insulated walls, heat units and convection fans. Optimally, the fans are able to keep airflow even so that heat is distributed equally throughout the oven space. Large fluctuations in heat across the oven can potentially affect the cycle time and material consolidation. Most specifically, this system should also be able to maintain the even heating with the rotating molds in place. The rotating mechanism must also be able to interface with the oven. For example, with one particular type of machine there is a central control unit that manages four or five arms. Each of the arms has a system that allows for molds to be mounted and also rotated biaxially. The door of the heating section of the processing area has a hole or slot through which this arm can extend into the oven cavity. This allows for the arm to perform its rotating function without interfering with the function of the oven. Biaxial rotation is one of the most common and best ways to get the particle material or powdered resin to cover the entire inside surface of the molds. After the heating cycle is done, the arm pivots to a cooling station. The cooling station is usually comprised of simply a spray system that uses water to remove the heat from the mold and part as quickly as possible. As soon as the first arm is moved from the oven, a second arm is rotated into the oven. The last zone is where molds are opened, filled and closed in preparation for entering the oven. Any other zones or equipment in the machine is designed to shorten the time and labor in these three basic zones.

2.3 Rotomolding Process

The process of rotomolding can be easily broken down into four basic steps that take place in these three zones. These include: mold fill, heating, cooling and part removal. Each of these is dependent on other factors. Mold fill, for example is heavily dependent on the mold style, mold fixturing and also the mold complexity. Mold fill is also directly dependent on the number of molds that are mounted to each of the machine arms. Heating also relies on the number of molds that are on each arm and the positioning of the molds. To ensure that each mold has sufficient heat for the cycle, the molds should be arranged with even and adequate spacing. Since cooling is a heat transfer process, similar to heating, the same things that affect the heating of the molds will also affect the cooling.

The first step in rotomolding is to take a thermally conductive hollow mold and fill it with the appropriate amount of resin. The resin is poured in as a powder with all accompanying additives and pigments according to part requirements. Resin can be measured by weight or by volume (Miles and Briston 1996). This can be done during processing or it can be allocated in pre-measured units that can help reduce cycle time and operator error. Once the resin and any other additives are inside the mold the mold is clamped shut and moved to the oven portion of the process. When there are multiple molds attached to a single machine arm, the fill process needs to be done with each of the various molds. It is also while the molds are open that any molded-in parts are added. For example, if durable threads are needed in the final part, metal thread inserts can be located within the mold during the fill operation. Some manufacturers will also use

something called drop boxes that allow for additional layers of plastic or foamed resin cores to be added after the first layer is in place. These drop boxes are insulated so the material inside them does not begin to melt until the drop box is opened. The drop boxes also need to be re-loaded after every cycle.

The molds in rotomolding must be thermally conductive. Typically molds are made of aluminum because their high thermal conductivity to cost ratio. Many rotomolded parts are simple and the most popular mold material is cast aluminum (Schwartz and Goodman 1982). Other materials could be used that are more thermally conductive than aluminum but the cost of the other materials is often prohibitive. Other, less conductive materials, that may cost less, can also be used, but because of the increased processing time in both heating and cooling the mold, the less expensive mold materials can potentially have a longer payback time. Also, as mentioned above, rotomolding is a low pressure process with pressures inside the mold less than about ten psi. Some of the other processing methods, such as injection molding, can easily produce and handle pressures above 5,000 psi. Rotomolding molds are typically vented so that any pressure buildup, even through thermal differences, can be easily equalized. When properly vented, even the aluminum molds are quite capable of handling these low pressures.

The final features of the mold are those that simplify part finishing. Features can be used to reduce flash and defects such as air pockets. Other features can be integrated to reduce secondary operations like flash cleanup. If final parts need holes for fill ports, gages or any other reason, non-conductive inserts can be placed accordingly. When done

correctly, these non-conductive inserts eliminate the need to cut the necessary holes (Harper 2006). These inserts simply stop material build-up in the designated areas because there isn't sufficient heat for the resin to soften or stick. By pre-planning parting lines, molds and parts can both be simplified and other secondary operations reduced. Proper part and mold design also takes part removal into account. Rather than twisting a thread insert onto a protruding stud they should be held in place magnetically. Sometimes the threaded inserts are pre-heated as they are located in the mold in order to help to make them integral to the part (Beall 1998). This reduces time both during part removal and during mold fill. Another issue is when part requirements create undercuts in the part. Undercuts are when a part can not pull directly out of the mold because a part of the mold directly interferes with this part removal. In the case of undercuts, the best option is to reconsider part requirements to eliminate all undercuts. In cases where undercuts can't be eliminated the mold needs to be evaluated for options that allow for part removal without undercut interference. Sometimes molds are made in more than two parts to accommodate necessary undercuts. Another option would be to have removable or sliding sections of a mold that simplify part removal. Whichever of the various options is chosen, the simplest and least time consuming option is best. All options to reduce time and efforts in part finishing lend toward a less expensive and higher volume production part.

Depending on the number of parts expected from a mold set, there are various ways to clamp a mold closed. Because of the long cycle times in rotomolding, any cycle time reduction can greatly reduce part costs. Many manufacturers will primarily use a toggle clamp set up on the molds. Using a large steel framework around the aluminum

mold adds some rigidity to the mold when all the toggle clamps are in place. Other molders use pneumatic clamping mechanisms in order to speed up processing. Prototype or short run molds are sometimes even held together with something as crude as bolts. On the other end of the spectrum, some fully automated systems use various computer controlled mechanisms to open and close molds throughout the entire process. Once the mold is filled and clamped closed it is moved to the next position in the process where the mold is heated and the material begins to be fused. Clamping the molds needs to be a simple and quick method. If the parting lines between mold halves is designed correctly, clamping molds closed can be as simple as toggle clamps. One major concern when clamping the mold parts together is proper alignment of the two halves of the parting line. When an interlocking surface is used near the part lines, the parting line in the final parts has a greater chance of being smooth and needing less post processing finish work (Crawford 1996).

By heating a large metal cavity there will always be expansion. With many materials there are also parts of the chemical released. Heating and chemical off-gassing can often combine resulting in a significant pressure increase in the mold. With some molds minor pressure increases are of negligible concern. However, as the mold size and surface area increase, pressure becomes more of a concern. It is not uncommon for a rotomolded part to be as large as 55 gallon drums and larger. With a mold this large or larger, a simple pressure increase of about 10 psi inside the mold can cause a great deal of damage to the mold and even cause injury in catastrophic failure. A mold lid that is three feet in diameter will see a total load increase of about 70 pounds with a 10 psi increase.

When the molds get up towards the typical sizes, pressure increases like this can be devastating to nearly any clamping system. To avoid issues with clamping systems and to avoid catastrophic failures molders use a venting system. The easiest way to vent the mold is by inserting a vent tube through the mold wall into the mold cavity. This can be a high temp plastic, polytetrafluoroethylene (PTFE) or other material that will not become part of the finished product (Harper 2006). One method is to have this vent tube extend beyond the powder pool so that none of the resin flows out through the vent. Another method is to insert some fibrous material into the tube. This fiber acts as filter medium keeping the resin inside the mold during the process. Venting can be simple but can improve part quality and reduce risk to mold and operators.

The majority of rotomolding systems in use today use a convection heating system similar to a standard convection oven used for baking. These can be heated by gas or electricity. They are usually well insulated to reduce heat loss during processing and have circulation fans in an attempt to keep the heat uniform throughout the oven area. Unfortunately these systems still have relatively poor efficiency as the molds rotate within a spherical envelope but the ovens are cube shaped. Dead zones in the corners of the oven can slow the heating of the mold and increase overall cycle time. Some manufacturers combat this inefficiency by changing the heating and cooling system entirely. One alternative to the convection oven style of heating is to use molds that can be heated with hot oil. This oil is heated to the appropriate processing temperature and then it is routed through a tube network that covers the entire mold. When the heat cycle is complete, the hot oil is changed to cold oil and the heat is removed through the same

system. The main disadvantage to the oil heating system is in the increased cost of the molds. Each mold set becomes more expensive to produce and maintain. Also, when a hot oil system is not properly maintained, industrial accidents become much more dangerous than a standard convection oven failure. Others are also looking to trade the convection ovens for an electrical resistance heating system that is applied directly to the molds so that less heat is lost and there is no need to heat the entire oven area. This lessens the immediate increase in mold costs but the systems are still in experimental phases and haven't been shown to be as effective as needed. Currently the electrical systems are only add-ons to a conventional oven system (Harper 2006).

Regardless of the heat source, the mold and resin must be heated. As heat increases and penetrates the mold the mold gets closer to and surpasses the melt temperature of the resin. However, the resin will not all melt at once. Instead the resin will soften a little at a time and slowly build a skin from the inside surface of the mold inward towards the center (Morton-Jones 1989). The rotating action of the mold imposes a sort of tumbling on the resin. This helps to conduct heat through the resin quicker as well as distributing the resin to the entire inside surface of the mold. As the mold rotates there is a pool of unmelted resin that flows across the lower portion of the mold. Rotation must be optimized so that this powder pool passes over the entire inside surface of the mold. Optimization of rotation is often finalized at a ratio near 4:1 depending on the part dimensions and contours. Gradually, as the heat continues to rise, the powder pool diminishes and the wall thickness of the part increases. The powder resin in the pool begins to stick the walls as the mold is heated because the resin arrives at the glass

transition temperature and becomes “sticky”. Full part consolidation becomes more complete as the temperature gets closer to the melt temperature of the resin. This allows for any air bubbles that are trapped in the resin to migrate out.

One of the best ways to monitor the temperature in rotomolding has been shown to be thermocouples that verify the internal air, the resin, the mold and oven air temperature all at the same time. The most critical of the four is the mold internal air temperature. While monitoring internal air temperature all the phase changes of the material can be observed throughout the process. The phase changes give a much better picture of the part and when the parts are complete. Many facilities are still only capable of monitoring the oven temperature. These systems are typically timed and unfortunately a large amount of parts are either undercooked or overcooked at the end of the cycle. Scrap rates in rotomolding are notoriously high compared to other process with heat control being a major issue (Crawford 2005).

Once the part has completed its cycle, it is moved from the heat zone to a cooling station. For the advanced molding systems that use heated oil lines, cooling is done through the same lines. All other molds that have heat conducted from the outside in are typically spray cooled with room temperature water (Rosato 1991). Optimized systems that monitor the internal temperature during heating are also able to watch for phase changes in the cooling cycle. In heating the phase changes of the resin keep the parts from being undercooked or overcooked (Crawford 2005). In cooling, the main reason for monitoring the phase changes is to not pull the part out prematurely and cause defects while still being able to pull the part as quick as possible.

As quickly as the part is cooled enough to remove, the mold is moved from the cooling area to a preparation area. In the preparation area, molds are opened and parts are removed. Once the parts are removed, the mold needs to be cleaned and dried. The part will generally need to be trimmed of all flash on the various parting lines. Secondary operations also need to be taken care of but they can often be taken care of at a different location. Some parts need holes cut, lids sliced off or other various operations. Some parts are also fixtured for increased flatness or alignment. Rotomolded parts also have post processing shrinkage. Some molders will post cure their parts in an oven at lower temperatures to help reduce and equalize the amount of shrinkage. With the parts removed to the secondary operation location and the molds cleaned and dried, the system is ready to be refilled and the process begins again.

2.4 Sintering Process Materials

Besides proper control on the process parameters in rotomolding, another important aspect to rotomolding is the resin that is used. Not only the polymer blend that is used but also the resin form have great importance in rotomolding. Each can affect how the material flows in the powder pool, how the material melts and also how the material all fuses together during processing. Generally, material in the plastics industry comes in a pelletized form. However, pelletized resin would flow too quickly in nearly all rotomolding molds. Pelletized resin acts somewhat like ball bearings and does not create a resin pool on any flat surfaces. This creates thin part walls along any flat surface and thicker areas in all corners where the resin lingers for more time.

The sintering processes use less pressure and mechanical interaction than many of the other processes. Raw plastic material is placed inside the mold in some sort of particulate form. The particulate form works best in sintering because there is a large surface area per pound of material. The greater the surface area of the material, the greater chance there is for full particle consolidation (Crawford 1996). This gives greater strength to the final product. Small particle size and large surface area are not the only requirements for strong solid parts. To distribute the heat through the particles, as they typically have low thermal conductivity, there is often a need for some sort of agitation. This is never as invasive an interaction as that seen in the melt processes but is rather a tumbling action that causes the particles to flow over each other. The flow needed for particle consolidation imposes certain requirements on the particulate material used in the sinter processes. The flow must be high enough to allow the particles to move relative to each other and promote heat transfer but also be low enough so that all details of the mold are covered and molded into the part. With a flow rate that is too high, the part details are much less pronounced and sometimes do not show adequately and often wall thicknesses are too uneven for correct parts. With a flow rate that is too low, bridging occurs, air is trapped and parts are unsuitable for use (Beall 1998). Proper flow is a combination of both material and particle shape. Often material choice is made wholly dependent on the part requirements. Due to chemical resistance, permeability, UV resistance or some other final product imperative, material changes may not always be possible. This fact imposes flow modifying requirements on changes to the particles.

Between particle shape and particle size as well as size distribution, the flow is optimized according to the mold and process equipment.

Because there is no physical disruption of the resin other than tumbling during rotation, the palletized materials do not melt enough to fuse solidly into part walls. Also, the relatively large diameter of the individual resin particles traps air. The small spheroid particles will soften on the surface and where they are touching they will begin to fuse. However, the touch-off points of the spheroids leave a great deal of open space. Even when the spheroids are able to achieve an ideal close-packed structure, there is still too much air space between the particles to allow for full consolidation during sintering in any reasonable period of time. This problem is seen as a reduction in part strength.

One of the best ways to resolve this issue is to increase the surface area per pound of material. This can be done by decreasing the size of the pellets or by grinding the pellets into a powder. One way that has been developed to increase the surface area per pound of material and thereby increase the fusibility of the material is called micropellitization. Significantly reducing the size of the pellets helps with the heat penetration during processing and allows for stronger, more fully fused parts. Micropellitization produces pellets but as their name implies, they are much smaller than standard processing pellets. The micropellet, unfortunately, carries with it some of the same problems that standard pellets have. One of the biggest problems is the flow properties of micropellets. Building uniform wall thickness in large flat areas becomes more difficult with micropellets because they tend to flow so quickly across a flat area. Currently, the one major benefit of micropellets over some other resin forms is that it is

more cost effective than pulverized materials, for example. Rather than processing the resin into pellets and then post-processing the pellets into powder, micropellets are made with a lower total processing per unit pound of material. The number of post processing steps is reduced thereby reducing the cost of the material (Harper 2006).

Pulverized resin or powder resin is another method of increasing the surface area per pound in molding resins and is by far the most common material in use today in rotomolding. Powdered resins are typically compounded before being pulverized to get the material properties and colors that are desired. This is because the tumbling nature of the process is generally insufficient for adequate color mixing and penetration during processing. Similarly, any other material property enhancing additives can be easily compounded into the resin before pulverization to get them fully mixed.

One of the disadvantages to pulverized resin material is the inconsistencies that can sometimes occur during pulverization. If all the pulverization parameters are not maintained, the powder can end up with features that will create flow problems. The most common problems are features like “tails” on each particle. These cause too much mechanical entanglement and will cause bridging in the more intricate parts of mold. This bridging results in air pockets or weak sections of the part and potential leakage zones for those parts that are intended to be tanks or vessels because of these weaknesses. Other inconsistencies typically have similarly negative effects on the final part (Crawford and Throne 2002).

2.5 Powdered Resin Testing

To verify that the resin will flow and pool as needed during processing, quality control testing should always be done. Testing increases an understanding of some of the properties of the resin and makes it easier to diagnose any problems that may arise during processing. The most common tests for rotomolding resins are the bulk density test and the dry flow test. The tests are performed on a representative sample of the material to be processed. Due to material settling during transportation samples should be taken from more than one location in the material container or thoroughly mix the material before sampling and use.

The bulk density test used in rotomolding is generally done in conjunction with the dry flow test. The material flows through a funnel as part of the dry flow test. As the material leaves the funnel some is caught by a measured cup below the orifice of the funnel. After the dry flow test is completed, the measured cup is scraped even with the top and the cup is weighed (ASTM D 1895-96). This gives a measurement of the bulk density of the sample material. Bulk density, as it is currently used, has very little issues. It is a simple test that gives a simple data point without much concern of operator errors. There are currently no major concerns with the bulk density test.

The dry flow test is a test that was originally developed for the injection molding and extrusion industries (Laws 2004). The test was developed to verify a material's ability to flow through the funnel on the machine so that the equipment wouldn't be starved for material during processing. The test equipment consists of a funnel built to the standard specs and a timing device. For testing, the funnel is filled with 100 times the specific

gravity of the material after molding (ASTM D 1895-96). More commonly, the funnel is filled with 100 grams of molding material (Crawford and Throne 2002). Then the bottom orifice of the funnel is opened as the time is started. When the material has all passed through, the time is stopped and the time is the flow rating for the material. Tests are reported in seconds and should be reported accurately to the nearest 0.2 seconds (ASTM D 1895-96).

The test procedure itself and its implementation are where most of the difficulties lie in the dry flow test. The apparatus is where the other problems arise. The procedure calls for the orifice of the funnel to be opened as the time is started. Due to variations in operator, in mood of the operator, time of day and many other potential factors the start of the timing can be off to a statistically significant degree. The procedure suggests that the time stop when all the powder has finished flowing through the funnel. However, some operators have interpreted this such that they watch the powder flow from the top of the funnel while others watch the flow from the side without a view of the remaining resin. Along with that, an individual operator's reaction time will also significantly affect the time recorded for the material.

The weaknesses of the apparatus begin with the specification on the funnel orifice. The tolerances on the orifice are so broad that with any given material there can be significant variations in flow rate. Another substantial weakness in the equipment specification is the lack of callout regarding the surface finish of the funnel. With no specification on the surface finish, the exact build is up to the quality control facility that requests the equipment to be made. Some equipment is finished out with a mirror surface

polish and others have gone to a rough, sandblasted finish. Mr. Dru Laws of Mity Lite Rotomolding has shown the considerable effect of the surface finish on the flow of the material. As it turns out, the rougher the surface, the faster the material will flow through the funnel (Laws 2004).

Each time the International Association of Rotational Molders (ARM) convenes a conference they try to also have their associated subcommittees meet. One of these committees is the Polyolefins Committee. Their main function is supposed to be the discussion and advancement of polyolefin materials in rotomolding. However, unofficially, this subcommittee has taken on the concern of material testing—both pre-molded materials and part testing after molding. One of the major concerns that has been raised is weaknesses of the dry flow test in particular. Members of the subcommittee have done testing to verify some of these weaknesses. In their meeting in October of 2005, many of the comments in the meeting were centered around the differences seen in test procedure. Each of the differences seen had an effect on the outcome of the test but remarkably also fell within the specified test parameters. Based on the varying results given by the dry flow test in evaluating rotomolding resins, it seems quite apparent that there is a great need for a new test to measure the flow properties of rotomolding resin.

The test for rotomolding resins needs to more closely resemble the circumstances that the resin will be subjected to during processing. There will be some conditions that will be less reasonable to simulate during testing, like high temperature conditions, but more of the processing parameters can be brought into the testing than are currently seen in the dry flow test. Because each mold will have a different surface finish depending on

the part requirements the test should also remove all mold dependent variables in the quality control evaluation. The test should, if possible, have a system that eliminates the need to specify a surface finish on the test equipment. With the dry flow test operator variation so common, it would also be beneficial to have little or no user interaction other than to start the test. Removing as much operator interaction as possible will reduce operator error to a large degree and will increase lab to lab comparison accuracy.

The proposed test uses a set of cylinders. The main cylinder functions as the test base. This cylinder is stationary and is closed off at the top. The second cylinder slides up and down along the base cylinder. The sliding cylinder is open on both both ends and the inside diameter of the sliding cylinder matches the outside diameter of the base cylinder with enough tolerance to slide smoothly during testing. There may need to be a friction ring to act as a sort of seal that keeps resin from sliding between the two cylinders but the closer these two fit together while still allowing for the cylinders to slide the better.

The base cylinder should have a smooth top. This allows for the least amount of equipment on resin interaction and a more independent reading. At the center of the top of the base there also needs to be a measuring device. The zero point of the measurement needs to be at the top of the base cylinder. It is anticipated that the measurement scale measure at least the same height as the diameter of the base cylinder. To be safe the measurement scale could be at least twice as high as the diameter of the base cylinder until some baseline data can be established. The scale needs to be as unobtrusive as possible.

This research will show an additional quality control test that can potentially work alongside or in place of the dry flow test. This work will delineate some of the optimal functions and features of a new potential test and will lay out and test one embodiment of this test.

EXPERIMENTAL PROCEDURE

3.1 Need For A New Test

While working on a fairly intricate rotomolded part, some of the necessities of rotomolding were made more evident. This part, as seen in Image 3A , has several details that required either mold modifications or tight material designation and control in order to reduce scrap rates. In one area, labeled Section 3A, the distance between two walls was originally less than one inch. In rotomolding, this small distance becomes a significant problem if the flow of the material isn't correct. Material can build between the two walls in what is called bridging. Unfortunately, this bridging occurs in an uncontrolled manner so as to never give repeatable features. It also makes the outer surface of the part either uneven and deformed from the outside or it causes pinhole defects. Within the same part are also other details, such as the lettering on the bottom and the eye details on the top of the part. These part features require material with a high flow to show all the detail that is designed into the part. Lastly, there are several areas on this part of large continuous flat or nearly flat surfaces. With high material flow in these areas the part walls are thin while the corners are thick.

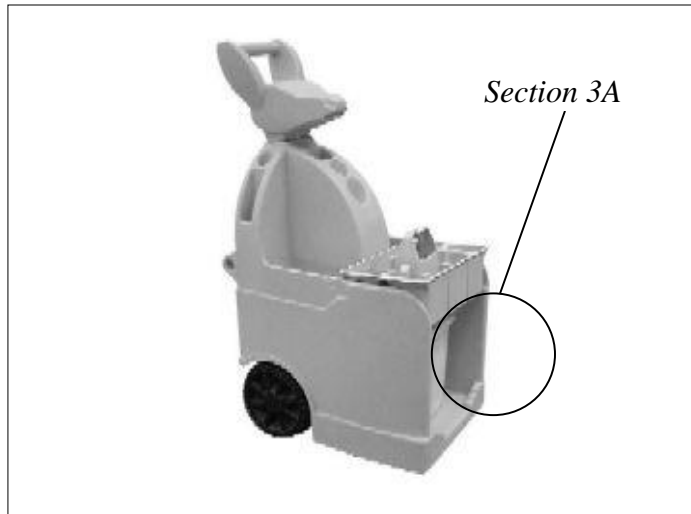

Figure 3A - Sample Rotomolded Part

Issues that arise from material flow can be solved with methods other than material specification. However, many of the solutions to material flow become exceptionally more complicated as more parts are processed simultaneously. For example, one solution to insufficient wall thickness is to direct more air at that mold area. By simply blowing compressed air through high temperature tubing that is aimed at the areas of concern, surrounding heated air will be directed to the same location. This additional air will increase the local mold temperature and the material will naturally accumulate there more quickly than other, relatively cooler, areas. With only one or two molds this solution is very straight forward and simple to execute. As the number of molds increases, in an effort to reduce the cost per part, precisely directing additional pinpoint airflow becomes more difficult. It can adversely affect the part removal and mold filling portions of the cycle depending on how the molds are mounted and where the airflow amplification system is needed. Because of concerns with these other

potential solutions a preferable solution to flow problems lies in improved testing and comprehension of the flow properties of the rotomolding resin. Adjustments can be more easily made with less of a negative impact on the cycle time of each part.

After many of the flow problems had been resolved with regards to the above project, it was sent to be presented at the national exposition for the Association of Rotational Molders International (ARM). It was presented as a new and innovative product in which new advances had been made. It was at this exposition and convention that a meeting was held by a subcommittee of ARM called the Polyolefins Committee. This committee is tasked with the development, promotion and advancement of polyolefin materials through discussion and collaboration. As part of their task, they have taken on the general testing of materials as well. Discussions were held on the current testing of materials and the effectiveness of the tests.

One of the tests that was under review was the dry flow test used on unprocessed materials. Mr. Dru Laws of Mity Lite in Orem, Utah had recently performed some analysis on the current dry flow standard. In one evaluation he had modified the inside surface finish of the test equipment by inserting industrially produced sand paper of various grits to see the effect of surface finish on the test. His concern on this was that surface finish could have a significant effect on the test but the test standard made no specification as to the surface finish of the funnel used for testing. Another evaluation he did was set up so as to differentiate errors or unacceptable variation in testing between operator error and equipment deficiencies. He wanted to know if he needed to do increased training with the individuals performing his testing or if the test itself was

lacking. He was able to show that there was indeed operator error but that there was also a significant amount of error that could not be accounted for by operator error only. These evaluations were the basis for a discussion of what could be done to improve the dry flow test so that material tests from one lab to another would be valid and accurate. In order to increase collaboration there had to be a common basis on which to discuss the status and progress of the materials.

It was during this discussion on the current dry flow test method and equipment that it was proposed to present a new test that does not rely on a funnel or surface finish. This new method would also be less susceptible to user error. Based on the principle of angle of repose, where all particulate matter has a natural angle of rest, this new test method would evaluate the material's propensity for flowing along the material itself. The angle of repose has been used for many years in geology, and many other related fields, to describe soils, sands and other similar materials. As soil, for example, is placed in a situation where it exceeds its natural angle of repose, the unstable soil will naturally slough off little by little until it returns to its natural state. In soils, the angle of repose depends on the material shape, the size of the particles, the temperature of the soil and the humidity of the soil. Soil with large smooth particles, like gravel, will show a flatter angle of repose than soil with a large amount of organic matter having rougher and sometimes elongated particles. All of this data that is important in studying the behavior of soil, can also greatly contribute to the understanding of material flow in rotomolding. The material shape, size, temperature and humidity all affect the flow of rotomolding powders. Controls are generally put in place to control temperature and humidity but particle size

and shape are not generally controlled by the processors but by the material suppliers. Having an increased understanding of the material flow with a decreased chance of operator and equipment error improves the ability to produce a better part with less failure.

3.2 Development

The first embodiment of an angle of repose test was to take a cup-like apparatus with an open top and closed bottom. In the flat plate of the bottom of the cylinder, a hole was cut at the center. Calibrated tick marks were placed along the inside of test cup to measure the angle of repose for the powder as it flows out the hole, as seen in Figure 3B.

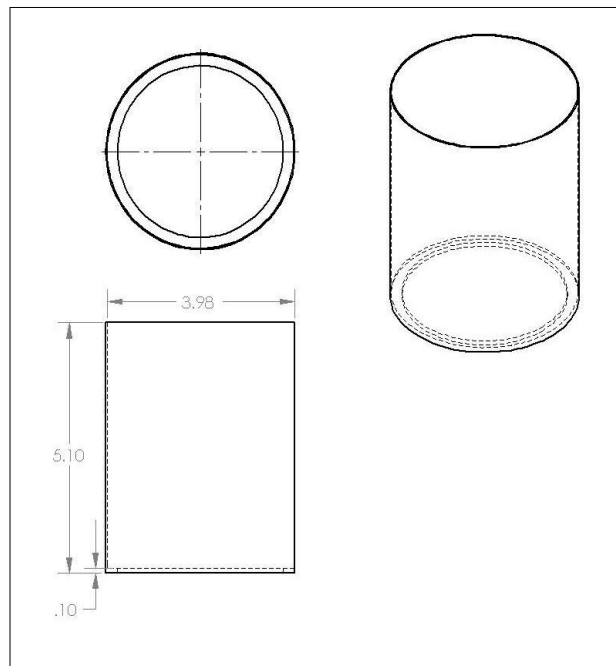
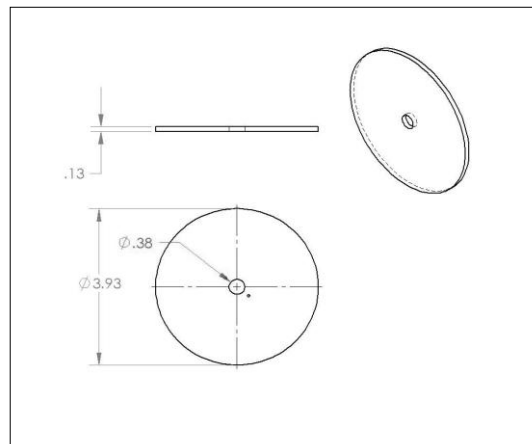
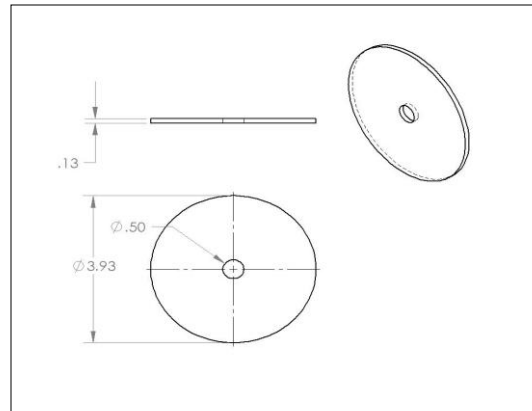

Figure 3B - Concave Angular Flow Test Fixture

To get more information about the different possibilities and needs for the test fixture, the cylinder was made to accept interchangeable bottom plates. The bottom plates were made from different materials, three from ABS sheet material, three from HDPE sheet material and three from steel. Each of the three plates in the three materials were had holes of different sizes, one hole was 3/8 inch (Image 3C), the second was 1/2 inch (Image 3D) and the third was 3/4 inch (Image 3E). Each of the plate options was tested with the same stainless steel cylinder. To test the different plates and hole sizes, each was tested with powder ABS rotomolding resin, powder LLDPE rotomolding resin and powder HDPE rotomolding resin. In evaluating the plates and hole sizes none of the three powders would flow through any of the three plates with any of the different hole sizes. The concept did not give repeatable results. Occasionally the powders would flow out of the cup and give a readable result but generally the resin would interlock and not create a flow angle of any kind.



*Figure 3C - Concave Angular Flow
Bottom Plate 0.38 Inch Hole*



*Figure 3D - Concave Angular Flow
Bottom Plate 0.50 Inch Hole*

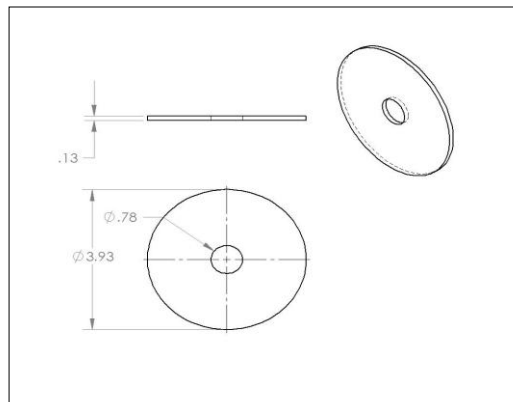

*Figure 3E - Concave Angular Flow
Bottom Plate 0.75 Inch Hole*

While performing these first tests with the equipment concept, the second angle of repose concept was developed. Because of the failure of the first concept in testing the material using a concave angle of repose, the concept of measuring a convex angle of repose to test the flow was tested. This was first done with the equipment for the first concept. It was noticed that using the equipment from concept one, a second smaller cylinder could be placed under the lower test plate. This second cylinder could both cover

the test hole and could also act as a plunger to push the plate and all material up and out of the cup while creating a convex angle of repose. These tests were independent of the hole size in the plates because the hole was blocked during the entire test. These first tests showed a noticeable difference between the three rotomolding powders but showed very little difference, if any, between the three different plate materials. From these tests, the final test fixture was designed.

Using the convex angle of repose testing presents a couple of issues. In order to test the material without operator errors, the test should be able to run with very little operator intervention. After the material is tested, it must be measured in some way. These two main issues were taken into consideration in the equipment design. One fully enclosed cylinder became the base of the apparatus. This was built from extruded acrylic with a polished smooth surface. This extruded tube was then capped on both ends with flat acrylic sheet. The bottom of this base cylinder was intentionally left larger than the cylinder but the top plate was trimmed even with cylinder. The second cylinder of this fixture was also extruded acrylic but this cylinder is left open on both ends. This became the sliding cylinder. The wall thickness of this cylinder was about 1/8 of an inch. The inside diameter was the same as the outside diameter of the base cylinder with a loose slip fit tolerance. The sliding cylinder glides smoothly and evenly up and down along the base cylinder with little resistance or effort. In order to reduce or potentially eliminate the operator error, a third cylinder was used. This cylinder was placed precisely on the large bottom plate of the base cylinder. The placement was such that the space between it and the base cylinder was even. The inside diameter of the third acrylic cylinder matched the

sliding cylinder. When assembled correctly, these three cylinders left a pocket with the sliding cylinder in the fully raised position as seen in Figure 3F. In conjunction with a small air valve in the outer base cylinder the weight of the sliding cylinder could work as a self regulating slide mechanism that needed only to be started and then no operator interaction is necessary.

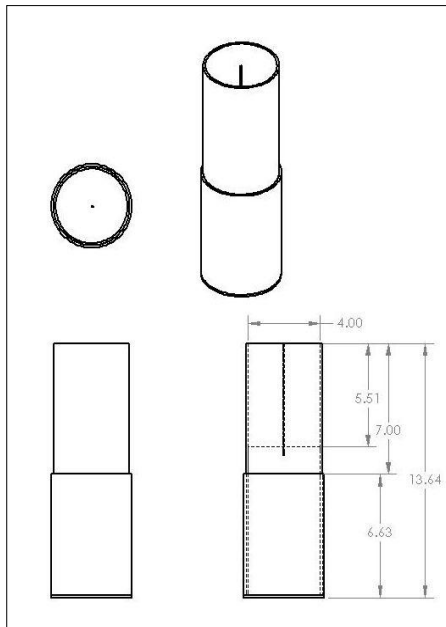
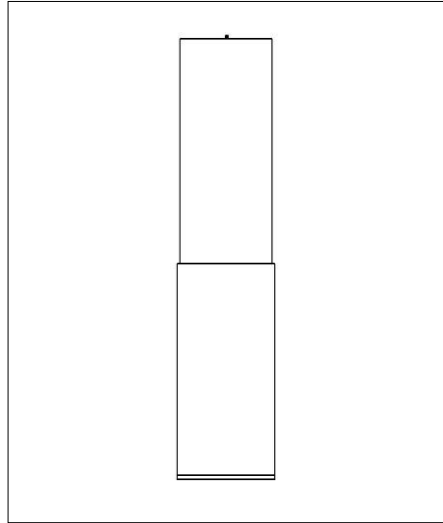

Figure 3F - Convex Angular Flow Test Fixture

With the first fabricated equipment prepared, the concept was again taken to the lab to do some basic testing with production materials. This was done with the sliding cylinder first in place at the top of the base cylinder (Figure 3G). In this position, the material was lightly scooped in the cup area created above the base cylinder.



*Figure 3G - Convex Angular Flow
Test Fixture: Up Position*

With the cupped area full of resin and the test equipment on a flat stable area, the sliding cylinder was slowly moved downwards. As the cylinder moved, the powder began to slough off on the top corners, beginning to form a measurable angle as seen in Figure 3H.

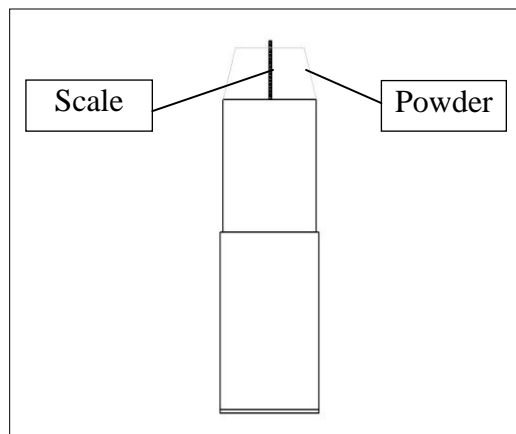

*Figure 3H - Convex Angular Flow
Test Fixture: Testing*

Moving the cylinder lower continued to drop increase the amount of material that sloughed off and exposed more of the scale as seen in Figure 3I. Also as seen in Figure 3I, the peak of the powder wasn't always centered on the scale but it was always measurable.

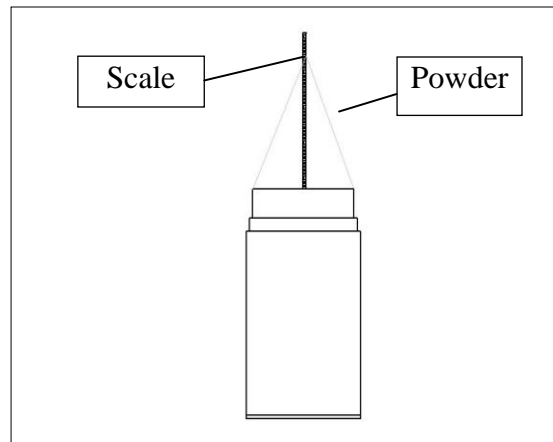

*Figure 3I - Convex Angular Flow Test
Fixture: Down Position*

After performing the first tests to ensure the viability of the new test method, it was noticed that there were some basic design or fabrication errors. It was seen that powder accumulation between the three cylinders eliminated the ability of the sliding cylinder to function as designed. This was either because the tolerances between the cylinders was too great or there was not an adequate seal between the cylinders. Also, the small air valve that was placed in the outer cylinder was not capable of regulating the movement of the sliding cylinder even when the powder was not deterring the movement. Because of these issues, the outer cylinder and the valve were removed for more evaluations. Without the outer base cylinder, the test equipment was shown to function. It

was tested on ABS, HDPE and LLDPE rotomolding powders and this testing showed that the procedure had potential to function as a possible test method for rotomolding. All three materials were shown to give a measurable reading and all readings from the three different materials indicated that the flow of each material was different.

Because of his involvement with the Polyolefins Committee of ARM, Mr. Dru Laws offered the use of the quality control facilities that he had access to for the full evaluation of the new test method. Not only did Mr. Laws have access to production materials that could be used in the evaluation, he also had some experimental materials, a dry flow test apparatus and the lab itself. The quality control lab was tightly controlled in temperature and humidity which helped to remove potential error factors. Both test apparatus, the old dry test and the new cylinder test, were set up. Four production materials and three experimental materials were conditioned inside the lab for 24 hours to ensure that they were at the proper temperature and humidity before testing. After the materials were prepared and the test procedure established all of the tests were performed.

RESULTS

4.1 Results

The basic premise of this research was to compare a new conceptual resin test called the angular flow test with the current standard in flow test called the dry flow test. The angular flow test was developed based on discussions of material flow with experts in rotomolding. The discussions included some of the weaknesses and problems that the dry flow test has. The needs of manufacturers with regards to material testing were also discussed. The manufacturers need to know how the powdered resin will flow during processing.

The two testing methods were evaluated in the same controlled environment. All evaluation materials were left to acclimatize in the same, low humidity, temperature regulated testing lab. Each of the various tests was performed with an untested sample of material. After each test, the tested material was placed into another container to keep the tested material away from the untested material. Four production materials and three non-production or experimental materials were used to evaluate the dry flow test method in comparison with the new proposed angular flow test method. Three samples from each of the seven materials were tested on each of the two testing apparatus for a total of 42 separate tests. All of the tests were performed in a randomized order selecting between the materials and the test methods. The test results were reported, in the raw data,

according to their separate test methodology. The dry flow test results were reported in seconds. The angular flow test results were all reported in the resulting height and all numbers are a measurement in millimeters.

The materials that were tested included four production materials and three experimental materials. The four production materials were those labeled as White, Brown, Gray and Dark Gray in the test results of the two tests. These materials were all polyethylene powders that were in use in the manufacturing of large flat rotomolded products. The material was designed to give a speckled look that closely resembled a stone product. The experimental materials were the ones labeled as Micropellets, Light Brown and Experimental White. The micropellets were polyethylene pellets of a very small cross-sectional diameter. They were not in use in any production part at the rotomolding facility where these tests were conducted but were in the lab as part of an evaluation of materials. The materials labeled Light Brown and Experimental White were in the lab as sample materials from a prospective supplier and had not yet been integrated into any product line.

4.2 Results From The Dry Flow Test Method

The tests performed on the dry flow test method yielded the raw data shown in table 4A. All tests on the old method are measured in seconds. Material was placed in the test apparatus with the bottom orifice closed off. The orifice was opened and the stopwatch was started. As soon as the material had passed through the test funnel the stopwatch was stopped. The time for the material to pass through the test funnel becomes

the data point for that test sample. All of the production materials gave results within a very narrow range but the experimental material results were much more broad. The micropellets flowed extremely well and resulted in a very low flow value. The white experimental powder had such a low flow rate that it didn't even leave the test apparatus.

Table 4A - Test Results From The Dry Flow Test

		Materials						
		White	Brown	Gray	Dark Gray	Micro-pellets	Light Brown	Experimental White
Test 1		26s	22s	27s	26s	19s	32s	No Flow
Test 2		27s	20s	28s	28s	19s	33s	No Flow
Test 3		26s	22s	26s	27s	19s	32s	No Flow

all test results reported in seconds

These results show that there is a large range of readings from one material to another. The micropellets, expectedly, show the greatest flow of all of the materials (minimum time). The experimental white material shows the least flow in that it did not even flow out of the funnel. The next material with the lowest flow is the light brown material. Between the highest and the lowest flow materials, that gave results, there is an average difference of 13.3 seconds. This gives something of a range to differentiate from one material to another.

4.3 Results From The Angular Flow Test Method

The tests that were performed on the new test method resulted in the data shown in table 4B. The outer cylinder of the new test method was slid to the top of the inner

cylinder creating a cup-like area between the two cylinders. The material test sample was placed in the cup area and any excess resin was scraped off to one side. Once the resin was scraped even with the top of outer cylinder, this outer cylinder evenly and smoothly slid down until the top of the outer cylinder is lower than the inner cylinder. All of the tests were done at the same speed with a focus on sliding the cylinder smoothly. With some of the materials, there was buildup between the two cylinders which made it more difficult to slide smoothly and gave invalid data. This was discovered during the preliminary benchmark tests so a step to wipe all resin off the testing equipment after every test was implemented. Wiping the equipment clean was meant to reduce drag and errors caused because of the drag.

Table 4B - Test Results From The Angular Flow Test

		Materials						
		White	Brown	Gray	Dark Gray	Micro-pellets	Light Brown	Experimental White
Test 1		58mm	58mm	55mm	50mm	28 mm	52 mm	55 mm
Test 2		58mm	53mm	55mm	51mm	30 mm	46 mm	70 mm
Test 3		54mm	54mm	50mm	50mm	35 mm	72 mm	69 mm

all results reported in millimeters

It is interesting to compare the raw data from the dry flow test to the angular flow test. In both tests the micropellets showed significantly faster flow than any of the other materials. Using the angular flow test method, the experimental white material gave measurable results even though the results were more widely spread than the other samples. This result is infinitely better than the results from the dry flow test because the

material was not testable in the dry flow apparatus. Also, of note, is the fact that in the dry flow test, the Brown production material appears to have a higher flow than the other production materials. This is interesting because in the angular flow test the Brown material flow was more in line with the other materials but the Dark Gray material showed a higher average flow than the rest. In production, these four materials were used on a very forgiving mold system and these two differences were not of significant note in production. However, in a less forgiving molding system, these differences would have been very important to observe. It is also important to note that these differences show that there is not a directly linear relationship between the two tests which also directly affects the analysis of the results somewhat.

The data shown for the Light Brown material has broad variation. This spread is because there were, during the tests moments of operator error. During the testing of this material, jostling of the equipment gave lower than accurate height readings. This jostling was the reason that the results from the Light Brown material were more sporadic than the results from the other tests. Because of the lack of a test result with which to compare the angular flow test to the dry flow test, the results from the Experimental White material were left out of the statistical analysis. Because of the obvious operator error during the angular flow tests for the light brown material, these results were not used in the final statistical analysis of the testing. However, in spite of this variation, the angular flow test was able to test beyond the range and ability of the dry flow test.

4.4 Statistical Analysis

In order to perform a statistical comparison of the two tests, the measurements had to first be converted to the same units. The test data was used to create a conversion equation as seen in Figure 4A. The first step was calculating some of the basic statistical values from the raw data, including standard deviation and mean. Once these numbers were generated, they were entered, along with raw data, into software that was then programmed to calculate a conversion equation. This was done by plotting the mean values based on the data. Then, a regression line is forced to this plot of the mean values. This regression line is a representation of the relation of the data. This regression line can be represented by an equation that can also be used as a conversion formula between the seconds data set and the millimeters data set. The equation for this set of data allowed for an evaluation in comparable units to increase the significance of the comparison.

$$f(x) = 0.24765x + 11.92364 \quad (1)$$

The data was then converted for all values of x where x equals some height in millimeters to a value s where s is seconds. All of the data from the angular flow test was reported in millimeters. Using this equation, the data from the tests on the angular flow test method were converted to seconds just like the data from the dry flow test. It must be said that this equation is a conversion according to the data given only. With additional data on more materials, this equation will need to be adjusted slightly to reflect more accurately a wider spectrum of testing.

With all the data in seconds, more statistical calculations were made. The most important of these calculations was that of a regression line that was calculated specifically along the data on both of the test methods, respectively. The regression line is used to give an estimate of variance, or error, for each test. As with the calculations for the equation, the variance for each test was calculated without the test results for the materials with the known errors. While preparing the data for the calculation of the estimate of variance, the statistician was under the impression that the old dry flow test would show a lower variation than the new test. These assumptions were based on the apparent variance in the raw data. However, after calculating the variance, the results were surprising to the statistician.

The final numbers show that the dry flow test had a variance of 0.73333 and the angular flow test had a variance of 0.41705. The dry flow test showed a variance that was nearly double that of the angular flow test. In spite of being double, though, this difference is not yet statistically different.

CONCLUSIONS AND RECOMMENDATIONS

5.1 Conclusions

The angular flow test is a resounding success. In terms of testing efficacy (materials capability), it has been shown to have a wider effective range in material testing than the dry flow test method. In terms of variance, it has been shown to have the same statistical error than the dry flow test under ideal conditions. The materials that were tested have been shown to be more accurately gauged by the angular flow test than was previously done by the dry flow test. Also, the potential for this test to increase repeatability in material verification in rotomolding raw materials is great as well.

The operation of the angular flow test is simpler than that of the dry flow test. There is much less detail in the test procedure that is left to interpretation and operator whim in the angular test than there is in the dry flow test. Besides the occasions where an operator might accidentally bump the test equipment during testing, there is less chance for the operator to cause false readings. The equipment surface finish is not a factor in accurate testing as all results are based on an interaction of resin to resin instead of resin to equipment. This feature simplifies the construction of the test apparatus and gives greater confidence that testing will be uniform from laboratory to laboratory. The resin does not flow through some test hole so the specification of a hole and its tolerances will not affect the testing. The diameter of the base cylinder will have an effect on the final

height of the angular test where this is not a factor in dry flow test equipment. However, this diameter is easily controlled. By and large, the operation of the angular flow test is more robust and more valid than that of dry flow test.

The angular flow test method piggy backs on angle of repose evaluations that have been done in geology for decades. The angular flow test relies on an extensive base of knowledge as many different soils, aggregates and sands have been tested and evaluated. These evaluations have been performed on the materials in different environments to tell a great deal. The great body of angle of repose data may need to be evaluated to see if there are additional insights that can be borrowed for the angular flow test. This great base that lies as a foundation to the angular flow test will lend credence to its acceptance as a manufacturing evaluation tool. Having a broad acceptance in industry will additionally increase the value of the test for manufacturers, designers and resin suppliers.

5.2 Importance Of The Angular Flow Test In The Rotomolding Industry

The dry flow test is in use in several facilities around the world, but not all. Rotomolding in general has room for progress to be made in many areas. One of the ways is in increased quality and decreased scrap rates. These will come, in part, through a greater understanding of the materials being used and the inherent properties of these materials. The angular flow test will open this door to more molders, material suppliers, compounders, designers, and others who have direct contact with the rotomolding industry. As a simpler and more reliable test than the dry flow test, the angular flow test

will allow for more in the rotomolding industry to have increased knowledge as they attempt to reduce their costs of manufacturing. Molders will have more power as they specify the materials that they need for complex parts and begin competing in areas of the industry that they were previously unable to handle. Suppliers will have greater confidence in guaranteeing the materials that they provide to perform as needed throughout the market. Compounders will have a greater ability to verify specialty orders for specific parts. New avenues could potentially open for a designer with the vision to see what can be done with the ability to designate a broader range flow in the materials than was previously possible to verify. The simplicity of the angular flow test could replace the dry flow test in many facilities and can fill a testing vacuum in others around the world.

This angular flow test is potentially a solution to broad weaknesses in the dry flow test. It is simple. It is repeatable. The degree of variance in the test is nearly half that of the dry flow test. The equipment itself can be significantly less expensive than the dry flow test. The angular flow test can easily have an extensive adoption throughout the world of rotomolding because of its many advantages over the dry flow test.

5.3 Suggestions

One of the first tasks concerning the new cylinder based flow test is to gain a more complete understanding of its potential application. It must be tested in more facilities to verify its use at the hands of multiple users and in many different facilities. The test procedures need to be evaluated to make sure that they are as simple as is needed

and do not leave anything to chance. It needs to be tested with materials. The linearity of the relationship between the dry flow and angular flow may also need to be investigated. The angular flow test has been evaluated using a handful of materials that run in one shop. By testing with the materials in use in a broader range of products and facilities a greater understanding of its effectiveness will be developed. It may be that materials of a finer grade are can be evaluated with greater precision than those seen through this work. Factors such as particle distribution, molecular weight, and pulverizing quality can show other details as they are tested that were not seen in these tests. Some work may be needed to enhance the test equipment or to simplify the equipment duplication process.

One possible approach to this increased evaluation of the angular flow test methodology would be to first publicly discuss the development of this test. RotoWorld is an industry accepted magazine where new research and advancements in rotomolding can be discussed. An article discussing the results of this experiment and its potential should be written to pique interest in a new resin test. Along with an article, a discussion should also be presented to the polyolefins committee of ARM. Based on that discussion, additional test fixtures could be built for testing in the various labs of the attending committee members. More data can be gathered and evaluated through standard quality assurance methods to verify the data of this work. The polyolefins committee can then make recommendations based on the additional data for more integration of the new test in the rotomolding industry. Because of the current widespread use of the dry flow test, full integration of the angular flow test will take some time and may not fully replace the

dry flow test for years, if ever. Even side by side use of the two tests, though, can improve testing repeatability and improve the quality in rotomolding.

During the broad evaluation of the angular flow test, some effort should be made to make the test less susceptible to the occasional bump by an operator. The bump and jostle that was seen in this work that directly affected the Light Brown material appeared to be caused, in part, by some of the fine resin particles among the particle size distribution spectrum. This smaller material seemed to slip between the two cylinders and increase the friction between them. This increased friction required greater force to perform the test and may have been the cause of a slight bump as the sliding cylinder reached the bottom of the base cylinder. This jamming may be possible to reduce by creating some sort of seal between the two cylinders or maybe by having tighter tolerances between the two cylinders. Perhaps another way to reduce incidental bumping of the apparatus would be to also have it weighted or mounted to a testing bench. More work needs to be done in this area to either understand the incidental operator error involved with the angular flow testing or to eliminate the issue.

Currently, operator error appears to mainly take place as the sliding cylinder moves from the fill position down. This error comes as the operator slides the cylinder and there is either a jolt at the end of the test that causes material to flow uncharacteristically because of the jostle or other factors may cause the cylinder to not slide smoothly which can affect the force applied by the operator. The jostle error alone could be reduced by lengthening the stroke of the sliding cylinder. By increasing the length of the base cylinder, the sliding cylinder will have moved to the point where the

test is complete before there is danger of jostling the equipment at the end of the stroke. To decrease material buildup between the two cylinders, there may be two solutions. First, the seal between the sliding cylinder and the base cylinder may need to be made from a stiff, thin material that is able to essentially scrape the inside of the sliding cylinder without causing too much friction. Second, there may need to be a relief depression on the base cylinder so that if any material does make it past the seal, there will be sufficient space between the two cylinders that buildup will not increase friction. Another possible solution to operator error concerns would be to create a system where the test is initiated by the operator but the remainder of the test is performed without operator contact. Concepts to accomplish this might include springs, air resistance cylinders, and even stepper motors. The more complicated these additional devices become, however, the more expensive the equipment will become and the less widely accepted the test will be. The most simple solution will be the most advantageous. Because of this, the air resistance system seems to have the most potential. Having the sliding cylinder weighted, it will slide evenly and on its own. This alone may be enough as there is some resistance offered by the resin inside the testing apparatus. In the case that it is not enough, there may need to be an enclosed air chamber created by aligning a third cylinder outside the sliding cylinder. The air chamber created between the two base cylinders, then, could be sealed off and pressurized by the sliding cylinder. As the sliding cylinder descends, air flow out of this small chamber may be regulated with a small needle valve placed in the new outside base cylinder. There are some drawbacks to this system (material may fall down between the cylinders creating a cleaning issue between

each test) that may not allow it to function, however, the more operator interaction that can be removed from the system, the more robust it will be.

The test should be adapted for worldwide use in all aspects of quality control within the rotomolding industry. The test has, according to the current testing, less variance (though it should be noted, not statistically different) than the current quality control as well as greater repeatability and broader application and as such it should be broadly adopted as a method for increasing productivity in rotomolding. The test should be submitted to one of the internationally recognized organizations that govern test methodology for approval and acceptance in their standards. By fulfilling the criteria of one of these testing oversight organizations, the test will be acceptable as an inter-organization data point for use in specifying or qualifying production materials.

REFERENCES

- ASTM Test Method D 1895-96; 2001 ASTM Reference Manual.
- Beall, G. L. *Rotational Molding, Design, Materials, Tooling and Processing*. Munich: Hanser Publishers, 1998.
- Bruins, P. F., ed. *Basic Principles of Rotational Molding*. New York: Gordon and Breach Science Publishers, 1971.
- Brydson, J. A. *Plastics Materials*. Essex: Anchor Press Ltd, 1989.
- Crawford, R. J., ed. *Rotational Moulding of Plastics*, Second Edition. Taunton: Research Studies Press LTD., 1996.
- Crawford, R. J. and J. L. Throne. *Rotational Molding Technology*. Norwich: Plastics Design Library William Andrew Publishing, 2002.
- Flinn, R. A. and P. K. Trojan. *Engineering Materials and Their Applications*. Boston: Houghton Mifflin Company, 1990.
- Harper, C. A., ed. *Handbook of Plastic Processes*. New Jersey: Wiley Interscience, 2006.
- Jacobs, J. A. and T. F. Kilduff. *Engineering Materials Technology*. Englewood Cliffs: Prentice-Hall, Inc., 1985.
- Laws, D. *An In-Depth Look at the Influential Factors of the Dry-Flow/Bulk-Density Test Used in the Rotomolding Industry*. Rotation: The Magazine of the International Rotational Molding Industry, Volume XIII, issue 1 (January-February, 2004).
- Morton-Jones, D. H. *Polymer Processing*. New York: Chapman and Hall, 1989.
- Miles, D. C. and J. H. Briston. *Polymer Technology*. New York: Chemical Publishing, 1996.
- Nugent, P. *Rotational Molding: A Practical Guide*. n.p., 2001.

Rosato, D. V., D. P. Di Mattia and D. V. Rosato. *Designing With Plastics and Composites: A Handbook*. New York: Van Nostrand Reinhold, 1991.

Schwartz, S. S. and S. H. Goodman. *Plastics Materials and Processes*. New York: Van Nostrand Reinhold Company, 1982.